

# Customer Equity: An Integral Part of Financial Reporting

Recent initiatives demand information that supplements and complements a firm's financial statements to bridge the gap between financial statement capabilities and financial reporting objectives. Such information assists investors' decision making by explaining the main trends and factors that underlie the development, performance, and position of the firm's business. Firms that aim to increase the value of their customer base should report forward-looking customer metrics because such reports align customer management with corporate goals and investors' perspectives. The authors propose a means to report customer equity that enables investors—the “consumers” of financial reports—to monitor firms' performance with respect to their customer assets. Furthermore, they develop a specific model for Netflix and apply it to quarterly data from September 2001 to September 2006.

*Keywords:* customer equity, decomposition, financial reporting, customer lifetime value

The objective of financial reporting is to provide information to help current and potential investors, creditors, and other users (hereinafter, investors) assess the amounts, timing, and uncertainty of prospective cash receipts (Financial Accounting Standards Board [FASB] 1978; International Accounting Standards Board [IASB] 2004). However, the IASB's (2004) *Framework for the Preparation and Presentation of Financial Statements* acknowledges that financial statements (e.g., balance sheets, profit and loss statements, notes) are not, on their own, sufficient to meet the objective of financial reporting. To bridge the gap between what financial statements are able to achieve and the objective of financial reporting, firms must report additional information that explains the main trends and factors that underlie their development, performance, and position (IASB 2005).

In response, the “Management Discussion and Analysis” (“MD&A”) required in the United States (Securities and Exchange Commission [SEC] 2003) and the recently discussed “Management Commentary” (IASB 2005) require information that supplements and complements information in a firm's financial statements. A recent report on the future of financial reporting published by the Big Six auditing firms confirms the importance of this discussion (Deloitte 2006). In Figure 1, we depict IASB's (2005, p. 12) view of financial reporting.

---

Thorsten Wiesel is Assistant Professor of Marketing, Faculty of Economics and Business Administration, VU University Amsterdam (e-mail: wiesel@wiesel.info). Bernd Skiera is Professor of Marketing and a member of the board of the E-Finance Lab, School of Business and Economics, Johann Wolfgang Goethe—University Frankfurt/Main (e-mail: skiera@skiera.de). Julián Villanueva is Assistant Professor of Marketing, IESE Business School (e-mail: villanueva@iese.edu). This research was supported by the E-Finance Lab (Frankfurt), the Emory Marketing Institute, Meta Kaasch Stiftung, and Stiftung der Deutschen Wirtschaft. The authors gratefully acknowledge the three anonymous *JM* reviewers for their feedback and suggestions. The authors are also thankful for comments and suggestions provided by Sonja Gensler; Marc Fischer; Kees Camfferman; Eelke Wiersma; and seminar participants at the University of Groningen, University of Nijmegen, ESADE Business School, Emory University, and VU University Amsterdam.

---

Specifically, the information requested in the “Management Commentary” should be future oriented, understandable, relevant, reliable, and comparable and should provide an “analysis through the eyes of management” (IASB 2005, p. 20). Examples of such information include details about the nature of the business, key resources, risks and relationships, and performance measures and indicators. Moreover, the IASB (2005) discussion paper explicitly mentions customer measures as crucial for assessing operating performance and, therefore, key information that should be reported to investors.

This call for more information is especially relevant for firms whose customers represent their primary assets because such firms aim to increase the value of their customer base through their customer management activities (e.g., Payne and Frow 2005; Reinartz and Kumar 2000, 2003; Reinartz, Thomas, and Kumar 2005; Rust, Lemon, and Zeithaml 2004; Ryals 2005; Venkatesan and Kumar 2004). Information about such activities exists within firms and is reviewed by management (e.g., Ambler 2000); if such information is important for managing the business, it also must be important to investors who want to assess performance and future prospects (PricewaterhouseCoopers 2005).

Consequently, firms should report forward-looking customer metrics (e.g., value of the customer base and its changes over time) in either the “MD&A” or “Management Commentary” sections to help investors—the “consumers” of financial reports—monitor firms' performance with respect to their customer assets and to communicate a customer value orientation to the financial community.<sup>1</sup> Such reporting would align with the described discussions about financial reporting and address recently mentioned research priorities focused on prescribing the critical marketing information elements that should be available to investors

---

<sup>1</sup>Note that we discuss an accounting measure of customer base value that can be used not in the primary financial statements (i.e., balance sheets) but rather in a supplementary section within financial reports (see Figure 1).

(Srinivasan and Hanssens 2007). Furthermore, reporting may support marketing's reentry into the boardroom because it aligns customer management with corporate goals and the investor's perspective (McGovern et al. 2004). However, thus far, such information has not been reported, and only limited research has addressed how to report the value of the customer base and its changes over time.

External reporting about a firm's customer management activities must fall in line with financial reporting criteria and thus focus on the value of the customer base rather than concentrating on short-term-oriented value metrics, such as current profitability. Therefore, investors should receive information about (1) customer metrics (e.g., customer retention, customer cash flow), (2) the value of the customer base (usually operationalized as customer equity), (3) components of customer equity (e.g., customer equity before marketing expenditures, total lifetime retention expenditures, total lifetime acquisition expenditures), (4) changes in customer equity and components of customer equity over time, and (5) the effects of changes in customer metrics over time. Such data would provide valuable information to investors.

A simple and illustrative example demonstrates our motivation for reporting forward-looking customer metrics rather than just short-term metrics. Assume that a company with contractual relationships reports the metrics in the first four rows of Table 1 for two subsequent periods. The metrics indicate that management has done an excellent job,

because they have significantly increased, which results in a boost in total cash flow by 31.43%. This kind of information is frequently reported. However, had the firm reported the next two rows of metrics (number of acquired customers and number of lost customers), overall assessments of this firm might change because the number of lost customers increased substantially, which leads to a much higher churn rate. If we consider the first eight rows of Table 1, evaluating whether management has done a good job is difficult because some metric changes are positive and others are negative. The overall effect remains unclear.

Using the available information to estimate a simple model of customer lifetime value (CLV) (for details, see Berger and Nasr 1998) shows that CLV diminished by 15.89%. Customer equity—defined here as CLV times the number of customers—also decreased by 7.87% (−\$4,602.54). Moreover, decomposing the change in value (i.e., which sources are responsible for the 7.87% decline in customer equity; we discuss this decomposition subsequently) increases insights into and facilitates evaluations of management's performance. In the example, the increase in cash flow per customer leads to a positive change in customer equity of \$11,690.28, but it is more than compensated for by a negative value effect due to the decreased retention rate (−\$16,647.09).

This simple example illustrates that forward-looking customer metrics provide more—and, in this case, different—insights than short-term metrics. Instead of congratulating management for increasing the current period's cash flow by 31.43%, investors should ask management why it created short-term value at the expense of long-term value. Furthermore, the decomposition clarifies performance because it reveals the forward-looking consequences of changes in the short-term metrics and visualizes the sources of change in customer equity.

To extend from this example, our main objective in this research is to highlight the importance of reporting forward-looking customer metrics in a firm's financial report. This addresses the recent demand for additional information that

**FIGURE 1**  
**IASB's View of Financial Reporting**

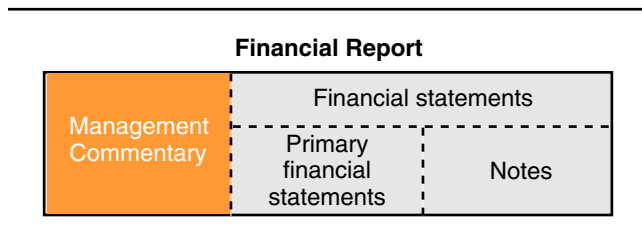

**TABLE 1**  
**Illustrative Example**

	Period 1	Period 2	Change (%)
Cash flow per customer (\$)	10.00	12.00	20.00
Total cash flow (\$)	10,500	13,800	31.43
Total number of customers (beginning of period)	1000	1050	5.00
Total number of customers (ending of period)	1050	1150	9.52
Number of acquired customers (during the period)	150	300	100.00
Number of lost customers (during the period)	100	200	100.00
Churn rate (%)	9.76	18.19	86.37
Retention rate (%)	90.24	81.81	−9.34
CLV (\$)	55.67	46.83	−15.89
Customer equity (\$)	58,451.42	53,848.88	−7.87
Change in customer equity (\$)		−4,602.54	
Due to changes in			
Cash flow per customer (\$)		11,690.28	
Retention rate (\$)		−16,647.09	
Number of customers (\$)		5,566.80	
Other (\$)		−5,212.53	

facilitates investors' decision making. In particular, we (1) emphasize the increasing need for forward-looking customer metrics to monitor customer management activities in financial reporting, (2) review a catalog of criteria relevant to financial reporting, (3) propose a technique to report the value of the customer base and its development over time, and (4) develop and apply a model that matches financial reporting criteria. Thus, we focus particularly on firms with contractual relationships (e.g., Internet service providers, financial service providers, telecommunication firms, energy suppliers, pay-television broadcasters, online movie rental services), which can easily determine the number of existing and lost customers at a particular point in time. Such determinations are more cumbersome for companies in noncontractual settings, which might need to modify this reporting technique.

We organize the remainder of this article as follows: The next section deduces a list of criteria relevant to financial reporting. Then, we propose a reporting technique that highlights the value of the customer base and its development over time. The subsequent section comprises a specific model that fits the proposed technique; we then apply this model to quarterly data from Netflix during 2001–2006. We conclude with implications and limitations of this model, as well as a discussion of further research.

## Critical Criteria for Financial Reporting

The IASB's (2004) *Framework for the Preparation and Presentation of Financial Statements*, the *Statement of Financial Accounting Concepts No. 2* (FASB 1980), and the "Management Commentary" discussion paper (IASB 2005) all present various qualitative characteristics of financial reporting, as we list in the first column of Table 2. Because international accounting standards and the U.S. financial accounting standards are similar in many aspects, with boards currently working to converge them, we emphasize critical criteria common to both sets of standards.

Information is relevant if it influences decision making by the recipients of financial reports (e.g., analysts, investors, regulators) because it improves their predictions or verifies their prior expectations. Nagar and Rajan (2005) show empirically that a set of customer relationship measures improves the explanatory power for the subsequent year's earnings by 10%–15%, and Fornell and colleagues (2006) indicate that investments based on customer satisfaction produce sizable excess returns with lower systematic risk. Accounting journals reveal extant research that advocates nonfinancial measures of company performance, such as customer satisfaction and loyalty, as useful indicators of aspects of firm performance (e.g., Amir and Lev 1996; Said, HassabElnaby, and Wier 2003; Smith and Wright 2004). Ittner and Larcker (1998) find a significant, positive relationship between customer satisfaction measures and future performance and discover that announcing such information creates excess returns; in other words, the disclosure of customer satisfaction measures provides information to the stock market about expected future cash flow. Internally, nonfinancial measures provide managers with good indica-

**TABLE 2**  
**Financial Reporting Criteria**

Qualitative Characteristics and Definitions	Derived Critical Criteria for Customer Equity Models
<b>Relevance</b> "The capacity to influence the economic decisions of users by helping them evaluate past, present, or future events or confirming or correcting their past evaluations."	Future orientation Decomposition
<b>Reliability<sup>a</sup></b> "Information has the quality of reliability when it is free from material error, faithfully represents that which it either purports to represent or could reasonably be expected to represent, and is free from bias."	Objectivity
<b>Comparability<sup>b</sup></b> "The quality of information that enables users to identify similarities in and differences between two sets of economic phenomena."	Comparability
<b>Understandability</b> "The quality of information that enables users to readily understand its significance."	Simplicity
<b>Benefit &gt; Cost</b>	Cost effectiveness

<sup>a</sup>In the IASB discussion paper, reliability consists of supportability and balance. "Free from material error" and "represents faithfully" appear in supportability, and "free from bias" is part of balance.

<sup>b</sup>The IASB discussion paper concludes that the ability to compare management commentaries from an entity over time is important because comparability between entities as a qualitative characteristic conflicts with the objective of requiring management to convey what it believes is important.

tions of the reasons for change in, for example, customer equity, which again benefits the firm's performance. For example, Ittner, Larcker, and Randall (2003) reveal that financial service firms that use a broader set of financial and nonfinancial measures earn higher stock returns. According to these studies, as well as that of Gupta, Lehmann, and Stuart (2004), financial analysts have yet to pay more than scant attention to these off-balance-sheet assets, even though they may be key determinants of a firm's market value. If a firm were to include information about the health of its customer relationships, investors would gain a better understanding of the link between a firm's customer assets and the capacity to generate shareholder value. The IASB (2005) discussion paper explicitly mentions customer measures as significant indicators that, for example, retail banks might use to assess operating performance.

Any measure of the health of a firm's customer relationships should account for future cash flows, so the FASB

(2000) accentuates the importance of discounted cash flow techniques. Measures of CLV and customer equity meet this criterion because of their future orientation and similarity to discounted cash flow techniques. Decomposing changes in customer equity into its components and isolating the effects of changes in customer metrics enable investors to evaluate better the long-term impact of the current performance.

According to the IASB (2005) discussion paper, measures also must exhibit reliability, in that they are free from material error and bias and faithfully represent that which they either purport to represent or could reasonably be expected to represent. The "Management Commentary" discussion paper addresses the first and third elements as forms of supportability, such that a measure is supportable if it faithfully represents, for example, information sources, inherent uncertainty, and material assumptions, which enable investors to assess the reliability of the measure for themselves. A prerequisite is objectivity in data collection and processing, so that different people computing the measure will obtain the same value. Being free from bias means that the measures evenly assess good and bad aspects of the firm's performance and prospects.

Comparability represents another important quality of financial reporting information that implies that the measure applies consistently across industries and time, so investors can compare the results for different firms over several years. The "Management Commentary" discussion paper refers only to comparability over time because comparability between entities conflicts with the objective of requiring management to convey what it believes is important. However, a customer equity reporting technique could be applied and compared among entities if it were standardized and did not depend on specific types of data. Because this requirement also refers to the criterion of simplicity, we emphasize comparability both over time and across entities.

Furthermore, all measures should be readily understandable and cost effective. They should rely only on a few inputs and ideally use secondary information collected within the firm. Any necessary primary data collection should be reduced to a minimum because of the associated costs and lack of comparability.

In line with the preceding discussion, we emphasize six critical criteria: future orientation, decomposition, objectivity, comparability, simplicity, and cost effectiveness. Many of these criteria also appear in a list of desiderata developed during a Marketing Science Institute (1999) workshop intended for brand valuation purposes, a context in which Fischer (2007) similarly developed six brand asset valuation criteria for an accounting measure of brand equity. We followed his argumentation and extended it to be in line with our customer equity reporting purpose.

In summary, firms should report forward-looking customer metrics (i.e., value of the customer base and its changes over time) to help investors monitor firms' performance with respect to their customer assets. These forward-looking customer metrics must be consistent with the criteria presented in Table 2. Subsequently, we propose a technique to report the value of the customer base and its

development over time that matches the financial reporting criteria.

## Customer Equity Reporting

### *"Customer Equity Statement"*

In general, customer equity reporting should comprise two main elements: the "Customer Equity Statement" and the "Customer Equity Flow Statement." The "Customer Equity Statement" reports customer equity (i.e., the value of the customer base) and its components in a single, clear display and thus reveals the value of the existing customer base. The "Customer Equity Flow Statement" describes changes in customer equity and its components between two periods and reports the influence of any changes in customer metrics on customer equity.

For the specific purpose of reporting, we define customer equity as the sum of the CLVs (after marketing expenditures) of all the firm's current customers in period  $t$  (Blattberg and Deighton 1996). The CLVs before marketing expenditures result from several customer metrics, such as cash flows generated by a customer (customer cash flow) and the duration of a customer's relationship with the company (customer lifetime). To retain or acquire customers, a firm must invest money; the measures of retention and acquisition expenditures per customer reflect those investments. Combining customer metrics with an appropriate discount rate provides a calculation of the net present value of a customer's cash flows (CLV before marketing expenditures), the net present value of a customer's acquisition expenditures (lifetime acquisition expenditures), and the net present value of a customer's retention expenditures (lifetime retention expenditures). We label these three metrics "customer value metrics" because they determine the value of a particular customer. Altogether, they determine each person's CLV (after marketing expenditures).

The number of customers at the end of a period equals the number of customers at the beginning of a period plus the number of customers acquired less the number of customers lost. To understand these customer movements, we use the number of existing customers (at the beginning of a period) and the number of new and lost customers (during a period) as "customer quantity metrics." Multiplying the CLV of an average customer before marketing expenditures by the number of existing, new, or lost customers provides the corresponding value of existing, new, or lost customers before marketing expenditures. We can perform a similar calculation for acquisition and retention expenditures. These various combinations of customer value and quantity metrics provide several different components of customer equity. As we illustrate in Figure 2, customer equity can be decomposed according to the kinds of customers (existing, new, or lost) or the value components (net present value of customer cash flows, retention expenditures, and acquisition expenditures).

In equation form, Figure 2 appears as follows, where the superscript  $E$  is existing customers at the beginning of the period,  $L$  is the number of lost customers during the period,

**FIGURE 2**  
**Decomposition of Customer Equity**

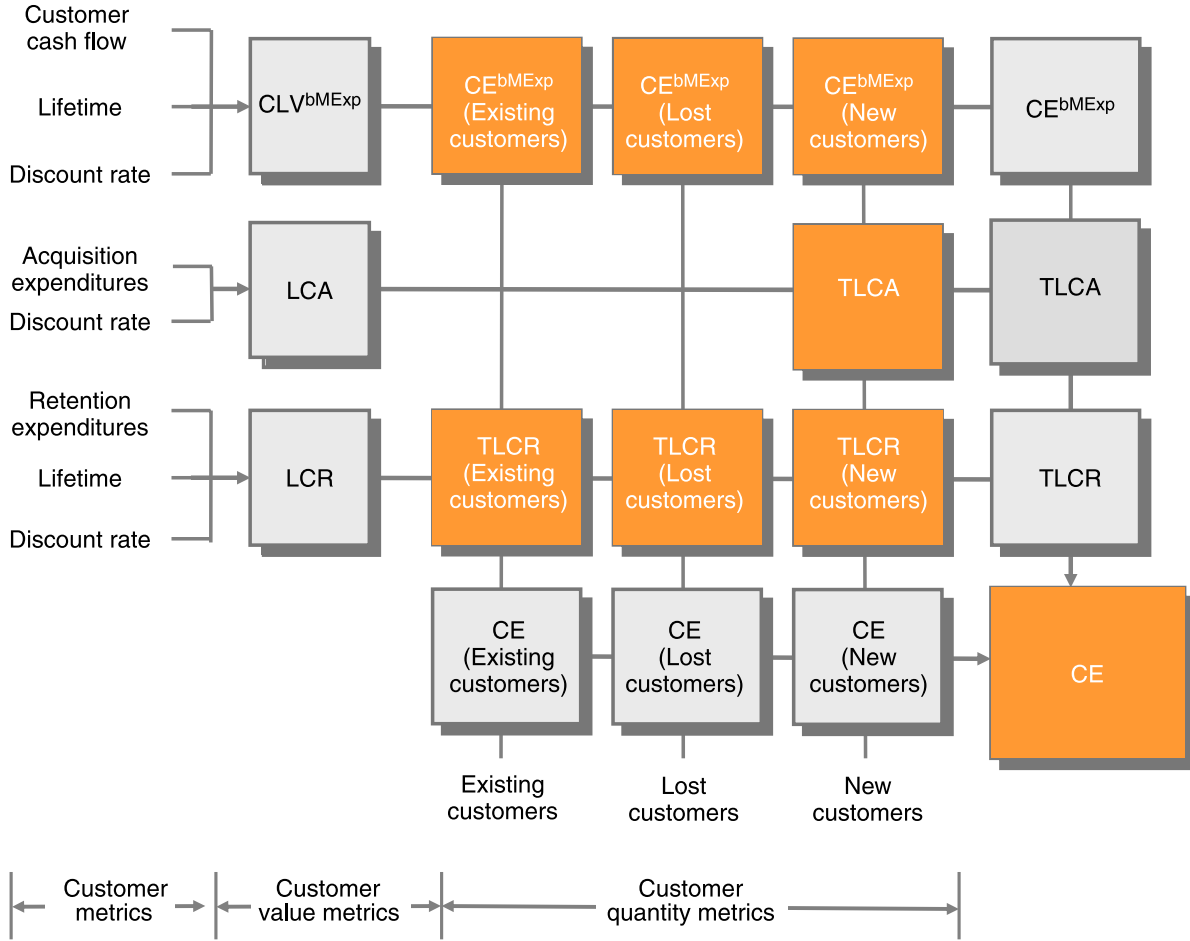

Notes: CE = customer equity,  $CLV^{bMExp}$  = customer lifetime value before marketing expenditures, LCA = lifetime acquisition expenditures, LCR = lifetime retention expenditures, TLCA = total lifetime acquisition expenditures, and TLCR = total lifetime retention expenditures.

and  $N$  represents the number of new customers in the period:

$$(1) \quad CE_t = f_t^E(\cdot) - f_t^L(\cdot) + f_t^N(\cdot) - h_t^E(\cdot) + h_t^L(\cdot) - h_t^N(\cdot) - g_t^N(\cdot) \\ = CE_t^{bMExp} - TLCR_t - TLCA_t,$$

where

- $CE_t$  = customer equity (after marketing expenditures) at the end of period  $t$ ,
- $f_t^{E(L,N)}(\cdot)$  = customer equity before marketing expenditures of the existing (lost, new) customers at the end of period  $t$ ,
- $h_t^{E(L,N)}(\cdot)$  = net present value of retention expenditures for the existing (lost, new) customers during period  $t$ , and
- $g_t^N(\cdot)$  = net present value of acquisition expenditures for the new customers during period  $t$ .

Thus, the sum of the first three terms in Equation 1 represents customer equity before marketing expenditures at the end of period  $t$  ( $CE_t^{bMExp}$ ) and corresponds to customer equity before marketing expenditures at the beginning of the period (first term) less the customer equity of lost cus-

tomers (second term) plus the customer equity of newly acquired customers (third term). The subsequent three terms represent the net present value of the retention expenditures ( $TLCR_t$ ), again divided into corresponding values for customers with the company at the beginning of the period, those acquired, and those lost. The last term in Equation 1 represents the net present value of the acquisition expenditures ( $TLCA_t$ ). Furthermore, we might rearrange Equation 1 to represent the value of different groups of customers, as follows:

$$(2) \quad CE_t = f_t^E(\cdot) - h_t^E(\cdot) - [f_t^L(\cdot) - h_t^L(\cdot)] + f_t^N(\cdot) - h_t^N(\cdot) - g_t^N(\cdot) \\ = CE_t^E - CE_t^L + CE_t^N,$$

where

- $CE_t^E = f_t^E(\cdot) - h_t^E(\cdot)$  = customer equity (after marketing expenditures) of existing customers at the end of period  $t$ ,
- $CE_t^L = f_t^L(\cdot) - h_t^L(\cdot)$  = customer equity (after marketing expenditures) of lost customers at the end of period  $t$ , and

$CE_t^N = f_t^N(\cdot) - h_t^N(\cdot) - g_t^N(\cdot)$  = customer equity (after marketing expenditures) of new customers at the end of period  $t$ .

Equation 2 states that customer equity (after marketing expenditures) at the end of the period equals the customer equity of existing customers after marketing expenditures ( $CE_t^E$ ) less customer equity after marketing expenditures of customers lost during the period ( $CE_t^L$ ) plus customer equity after marketing expenditures of newly acquired customers ( $CE_t^N$ ). Thus, we decompose customer equity according to its value components (customer cash flows, retention expenditures, and acquisition expenditures) and groups of customers (existing, new, or lost). A wide range of customer equity models, such as those proposed by Blatberg and Deighton (1996), Rust, Lemon, and Zeithaml (2004), or Gupta, Lehmann, and Stuart (2004), can be used to specify  $f_t(\cdot)$ ,  $h_t(\cdot)$ , or  $g_t(\cdot)$ ; for a recent review of different customer equity models, see Kumar and George (2007).

### “Customer Equity Flow Statement”

The “Customer Equity Flow Statement” illustrates changes in customer equity between two periods—that is, the difference between customer equity at the end of period  $t$  and  $t - 1$ :

$$(3) \quad \Delta CE_{t,t-1} = CE_t - CE_{t-1}$$

We can easily extend Equation 3 to calculate changes in customer equity among more than two periods. If we combine it with Equation 1, we further can decompose changes in customer equity into differences according to the number of existing, new, or lost customers. Moreover, knowledge of the exact specification of  $f_t(\cdot)$ ,  $h_t(\cdot)$ , or  $g_t(\cdot)$  would enable us to determine the effect of customer metrics on changes in customer equity.

## Application

### Objectives

We apply our reporting technique to Netflix. In doing so, we provide a possible specification of  $f_t(\cdot)$ ,  $h_t(\cdot)$ , or  $g_t(\cdot)$  that suits the available data. However, note that the “Customer Equity Statement” and the “Customer Equity Flow Statement” could handle other specifications, which we address in the “Discussion and Conclusion” section. Netflix’s principal activity is to provide online movie rental services through access to more than 55,000 movies, television, and other entertainment titles. The standard subscription plan gives customers up to three titles at the same time with no due dates, late fees, or shipping charges. Shipping and receiving centers throughout the United States deliver the DVDs through the U.S. Postal Service at no charge to customers.

Because Netflix is listed on the NASDAQ, it must fulfill several SEC requirements, such as the “MD&A” section in its financial reports. In its 10-Q statements, Netflix (2006) provides information about customer churn and customer acquisition costs and notes that management not only reviews churn rates to evaluate whether the company is

retaining existing customers, in accordance with its business plans, but also reviews acquisition expenditures to evaluate the efficiency of marketing programs for acquiring new customers. Furthermore, the statements indicate that Netflix believes in the usefulness of monitoring these metrics together, not individually, because it will not make business decisions based on a single metric. Although these metrics are measurable and observable by investors over time, they contradict several requirements of financial reporting; their interpretation is far from simple because investors must trade off between any changes in the metrics to determine the overall, long-term effect.

### Data

We use publicly available, quarterly data from annual reports, 10-K and 10-Q statements, and other company reports from September 2001 to September 2006. The data for each quarter include the number of customers, average monthly churn rate, gross subscriber additions, subscription revenue, subscription costs of revenue, operating expenses (without marketing expenditures), acquisition cost per customer, and marketing expenditures.

This information enables us to calculate the number of lost customers during the quarter (i.e., difference in the number of customers between the current and previous quarter plus gross additions in the current quarter). We calculate the average quarterly retention rate as  $1 - (\text{number of lost customers during the quarter} / \text{average number of customers during the quarter})$ . To calculate the cash flow per customer, we subtract the subscription costs of revenue and the operating expenditures from the subscription revenue and divide the result by the number of customers. To smooth out seasonal fluctuations and other one-off effects, we use a common financial practice called a “trailing 12-month average” and replace the cash flow per customer and quarter, as well as the quarterly retention rate, with the mean of the corresponding cash flows and retention rates for the preceding four quarters. Multiplying the number of customers acquired by the customer acquisition cost yields the acquisition expenditures, which equal the marketing expenditures of Netflix; that is, Netflix considers all its marketing expenditures acquisition expenditures. Thus, Netflix claims that its retention expenditures are zero.<sup>2</sup> The company provides no information about its discount rate, so we choose an annual discount rate of 10% (quarterly discount rate amounts to 2.41%).

In Table 3, we list our calculations for the different customer metrics, as well as the resulting customer metrics for the preceding four quarters (Q4 2005–Q3 2006). Figure 3 illustrates the value and changes of customer metrics over time. On the positive side, Netflix increased its number of customers and its retention rate, as well as the cash flow per customer, in 2006 after suffering a drop in 2005. However, its acquisition expenditures increased. Thus, these measures

<sup>2</sup>Some of Netflix’s technology and development expenses may result from the “member” portion of its Web site and thus reflect retention expenditures. Unfortunately, it is difficult to disentangle acquisition, retention, and general purpose of these expenditures. Therefore, we do not use them to determine retention expenditures.

**TABLE 3**  
**Calculation of Customer Metrics**

	<b>Calculation Method or Data Source</b>	<b>Q4 2005</b>	<b>Q1 2006</b>	<b>Q2 2006</b>	<b>Q3 2006</b>
Number of customers (in thousands)	Reported number of customers per quarter (source: financial statements)	4179	4866	5169	5662
Number of new customers (in thousands)	Reported number of gross subscriber additions (source: financial statements)	1156	1377	1070	1310
Number of lost customers (in thousands)	Difference in number of customers between the current and the previous quarter + number of gross additions in the current quarter	569	690	767	817
Customer cash flow (\$)	(Subscription revenue – subscription cost of revenue – operating expenses without marketing)/number of customers	9.97	10.84	11.87	12.60
Retention rate	$1 - [\text{number of lost customers during quarter}/(\text{number of customers at the beginning of quarter} + \text{number of customers at the end of quarter})/2]$	.83	.84	.85	.85
Retention expenditures per customer (\$)	(Reported marketing expenditures – reported acquisition cost per customer × number of new customers)/(number of customers – number of new customers)	.00	.00	.00	.00
Acquisition expenditures per customer (\$)	Reported acquisition cost per customer (source: financial statements)	38.08	38.47	43.95	45.32

do not provide a clear picture of the overall value of the customer base. To obtain that picture, we must specify  $f_t(\cdot)$ ,  $h_t(\cdot)$ , or  $g_t(\cdot)$  in accordance with the available data, as we do in the next subsection.

### Model

Although our formulation in Equations 1 and 2 is flexible enough to capture a wide range of specifications, data availability limits the feasibility of some models in our application. Our available information allows us to calculate only average values, such as average cash flow per customer, so we build on Berger and Nasr's (1998) ideas and select a parsimonious, easily applicable CLV specification (see also Gupta and Lehmann 2003; Kumar, Ramani, and Bohling 2004). This specification provides an example of a particular formulation of a customer equity model for financial reporting purposes; additional information, such as the metrics according to different customer segments, would enable us to capture heterogeneity across different customer segments and use alternative model formulations.

*Calculating CLV before marketing expenditures, lifetime retention expenditures, and lifetime acquisition expenditures.* The CLV before marketing expenditures of a current customer  $i$  in period  $t$  ( $CLV_{i,t}^{bMEExp}$ ) reflects the present value of the customer's cash flows ( $C_{i,t+t'}$ ) over his or her remaining lifetime ( $T_i - t$ ), with  $k$  as the discount rate:

$$(4) \quad CLV_{i,t}^{bMEExp} = \sum_{t'=0}^{T_i-t} \frac{C_{i,t+t'}}{(1+k)^{t'}}$$

To develop an average  $CLV_t^{bMEExp}$ , we assume that retention rates, which reflect the behavior of an average customer, are constant over time ( $T_i \rightarrow r_t$ ) and that the customer cash flows of an average customer are also constant over time ( $C_{i,t+t'} = C_t$ ). Using these assumptions, we can rewrite Equation 4 to describe the lifetime value of an average customer:

$$(5) \quad CLV_t^{bMEExp} = \sum_{t'=0}^{\infty} \frac{C_t \times r_t^{t'}}{(1+k)^{t'}} = \frac{C_t \times r_t^0}{(1+k)^0} + \frac{C_t \times r_t^1}{(1+k)^1} + \dots$$

Because Equation 4 is an infinite geometric series for  $|r/(1+k)| < 1$ , we also can rewrite it as

$$(6) \quad CLV_t^{bMEExp} = C_t \times \frac{1+k}{1+k-r_t}$$

According to Equation 6, we recognize that lifetime retention expenditures (LCR<sub>t</sub>) equal Equation 7 in the case of constant retention expenditures over time (CR<sub>t</sub>). Thus, we assume that retention expenditures occur in all periods:

$$(7) \quad LCR_t = CR_t \times \frac{1+k}{1+k-r_t}$$

The lifetime acquisition expenditures (LCA<sub>t</sub>) equal the current acquisition expenditures (CA<sub>t</sub>) if they occur only in the acquisition period. Otherwise, we must calculate the net present value of the acquisition expenditures. The CLV after marketing expenditures for existing customers,  $CLV_{E,t}^{bMEExp}$ ,

**FIGURE 3**  
**Development of Customer Metrics Over Time**

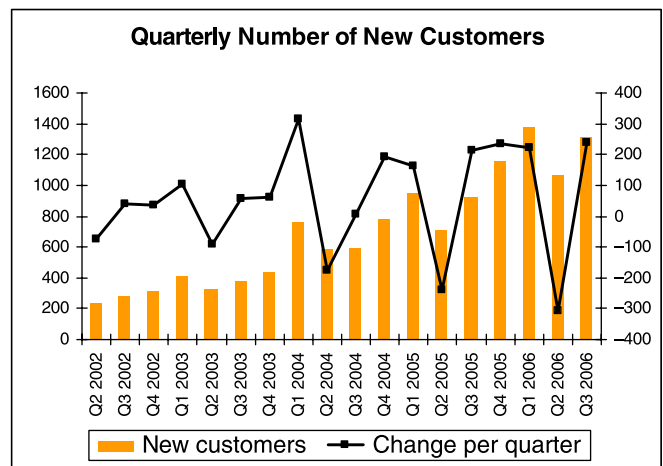
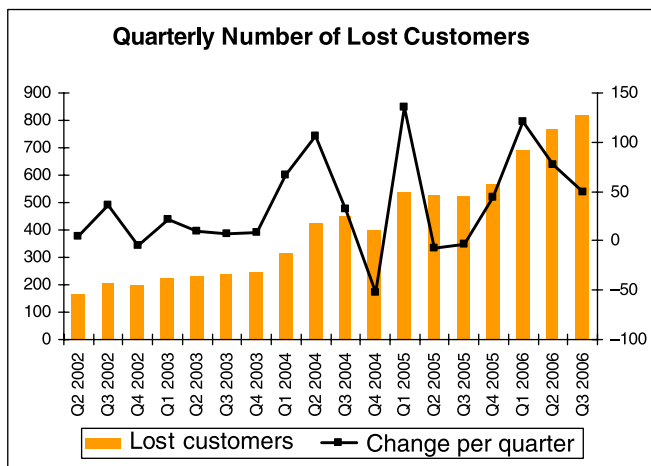
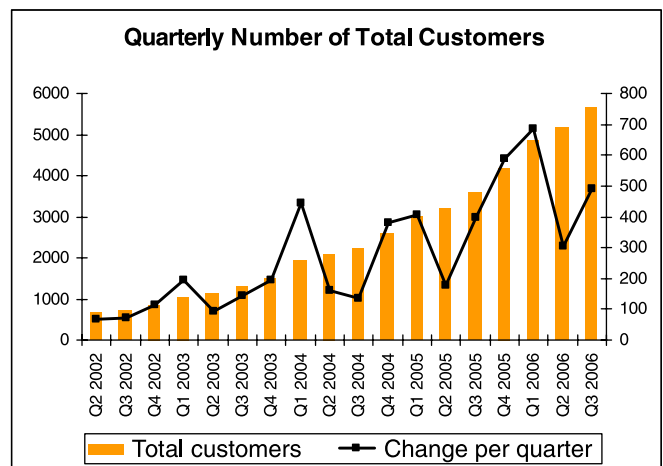
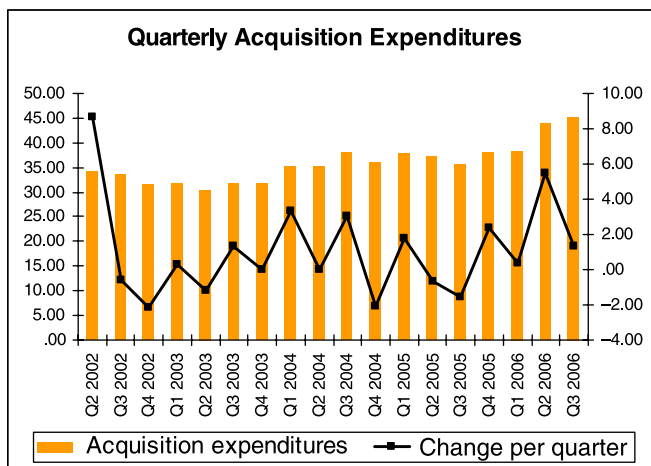
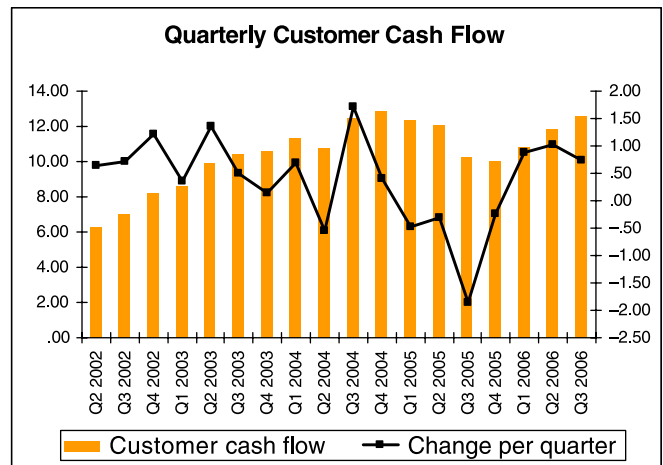
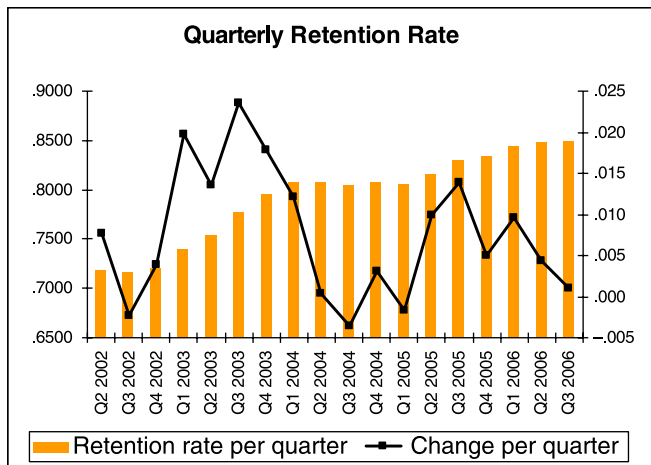

is  $CLV_t^{bME_{Exp}}$  less  $LCR_t$ , whereas that for new customers,  $CLV_{N,t}^{bME_{Exp}}$ , equals  $CLV_t^{bME_{Exp}}$  less the sum of  $LCA_t$  and  $LCR_t$ .

To assess Netflix, this particular formulation for calculating CLV works well and fulfills the criteria for financial reporting. However, we note the potential issues involved in our use of constant retention rates and the “gone-for-good”

assumption; both Kumar and Reinartz (2005) and Fader and Hardie (2006) show that using Equation 6 to calculate CLV might underestimate the value of the customer base if customer retention rates are heterogeneous. In that case, Equation 6 might include a factor that adjusts for the heterogeneity of retention rates across customers (Fader and Hardie 2006). Alternatively, we could estimate the equation sepa-

rately for homogeneous customer segments. Neither approach is applicable to our illustration because of the limited information availability, but they could be adopted easily if additional data were available. Although this limitation might bias the results, we note that the main objective of the “Customer Equity Flow Statement” is to track the development of customer equity over time. Therefore, if the heterogeneity of retention rates remains constant over time, the bias largely cancels itself out in the relative comparisons across different points in time. In addition, strong heterogeneity underestimates both CLV before marketing expenditures ( $CLV_t^{bME_{Exp}}$ ) and lifetime retention expenditures ( $LCR_t$ ). Thus, the amount of bias should cancel out at least partly because CLV after marketing expenditures subtracts  $LCR_t$  from  $CLV_t^{bME_{Exp}}$ .

Rust, Lemon, and Zeithaml (2004) also demonstrate the gone-for-good assumption bias, in that customers may return. This assumption biases calculations in two ways: First, it may underestimate the value of a customer (before marketing expenditures), who might eventually return and generate new cash flows. Second, it can underestimate acquisition expenditures for new customers because some “new” customers may be “reactivated” customers, in which case it may be more expensive to convince them about service improvements, for example. Acquisition expenditures related to these customers also may be overestimated if customers cancel the service as a result of a temporary absence (i.e., being abroad for six months). Netflix does not disclose any further information about the number of new customers and acquisition expenditures, but we posit that these opposing effects on CLV (before marketing expenditures) and acquisition expenditures should cancel each other out at least partly and thus limit the possible bias of the gone-for-good assumption.

“*Customer Equity Statement.*” When we combine Equations 1, 6, and 7, we obtain the following specification for customer equity ( $CE_t$ ) at the end of period  $t$ :

$$(8) \quad CE_t = N_t \times C_t \times \frac{1+k}{1+k-r_t} - N_t \times CR_t \\ \times \frac{1+k}{1+k-r_t} - N_t^N \times CA_t.$$

The first term on the right-hand side of Equation 8 represents our specification of  $f_t(\cdot)$ , the second term represents our specification of  $h_t(\cdot)$ , and the third term represents our specification of  $g_t(\cdot)$ . We choose this specification because it suits the available data, but we note that our reporting technique is also able to capture other specifications, which we address in the “Discussion and Conclusion” section. We determine customer equity according to customer metrics ( $C_t$ ,  $r_t$ ,  $CR_t$ , and  $CA_t$ ) and customer quantity metrics ( $N_t$  and  $N_t^N$ ). Using the concepts we described previously, it is straightforward to build on the ideas of Equations 1 or 2 and to further decompose Equation 8 into customer equity components.

“*Customer Equity Flow Statement.*” The “Customer Equity Flow Statement” provides information about absolute changes in customer equity and its components

over time. Equation 9 determines the change in customer equity between periods  $t$  and  $t - 1$  and can be easily modified to calculate changes in the components of customer equity:

$$(9) \quad \Delta CE_{t-1,t} = CE_t - CE_{t-1} \\ = \left[ \left( N_t \times C_t \times \frac{1+k}{1+k-r_t} - N_t \times CR_t \right. \right. \\ \left. \left. \times \frac{1+k}{1+k-r_t} - N_t^N \times CA_t \right) - \left( N_{t-1} \right. \right. \\ \left. \left. \times C_{t-1} \times \frac{1+k}{1+k-r_{t-1}} - N_{t-1} \times CR_{t-1} \right. \right. \\ \left. \left. \times \frac{1+k}{1+k-r_{t-1}} - N_{t-1}^N \times CA_{t-1} \right) \right].$$

The influence of any particular changes in customer metrics on customer equity appears in the difference in customer equity that results from a change in that particular metric. For example, the influence of changes in the number of existing customers between periods  $t$  and  $t - 1$  on customer equity before marketing expenditures is as follows:

$$(10) \quad \Delta N_{t-1,t}^{E,f} = f_t^E(N_{t-1}, C_{t-1}, L_{t-1}) \\ - f_{t-1}^E(N_{t-2}, C_{t-1}, L_{t-1}) \\ = N_{t-1} \times C_{t-1} \times \frac{1+k}{1+k-r_{t-1}} \\ - N_{t-2} \times C_{t-1} \times \frac{1+k}{1+k-r_{t-1}} \\ = (N_{t-1} - N_{t-2}) \times C_{t-1} \times \frac{1+k}{1+k-r_{t-1}}.$$

The model for reporting customer equity is consistent with the criteria presented in Table 2: It accounts for future cash flows (future orientation), decomposes customer equity and changes in customer equity (decomposition), uses accounting or other objective data as inputs (objectivity), is standardized and does not depend on specific data (comparability), is easy to understand for decision makers (simplicity), and does not require costly data collection because it uses data already available in the firm (cost effectiveness).

### Netflix’s “Customer Equity Statement”

In Figure 4, we depict Netflix’s “Customer Equity Statement” for Q3 2006, on the basis of Figure 2. Customer equity yields \$358.56 million in Q3 2006, according to the customer equity without marketing expenditures for existing customers (\$381.54 million), lost customers (−\$60.30 million), new customers (\$96.69 million), and total lifetime acquisition expenditures (−\$59.37 million). Because Netflix spends all its marketing expenditures on acquiring new customers, the total lifetime retention expenditures are always zero. We also demonstrate the decomposition according to groups of customers in Figure 4.

**FIGURE 4**  
**Netflix's Customer Equity Statement (Q3 2006)**

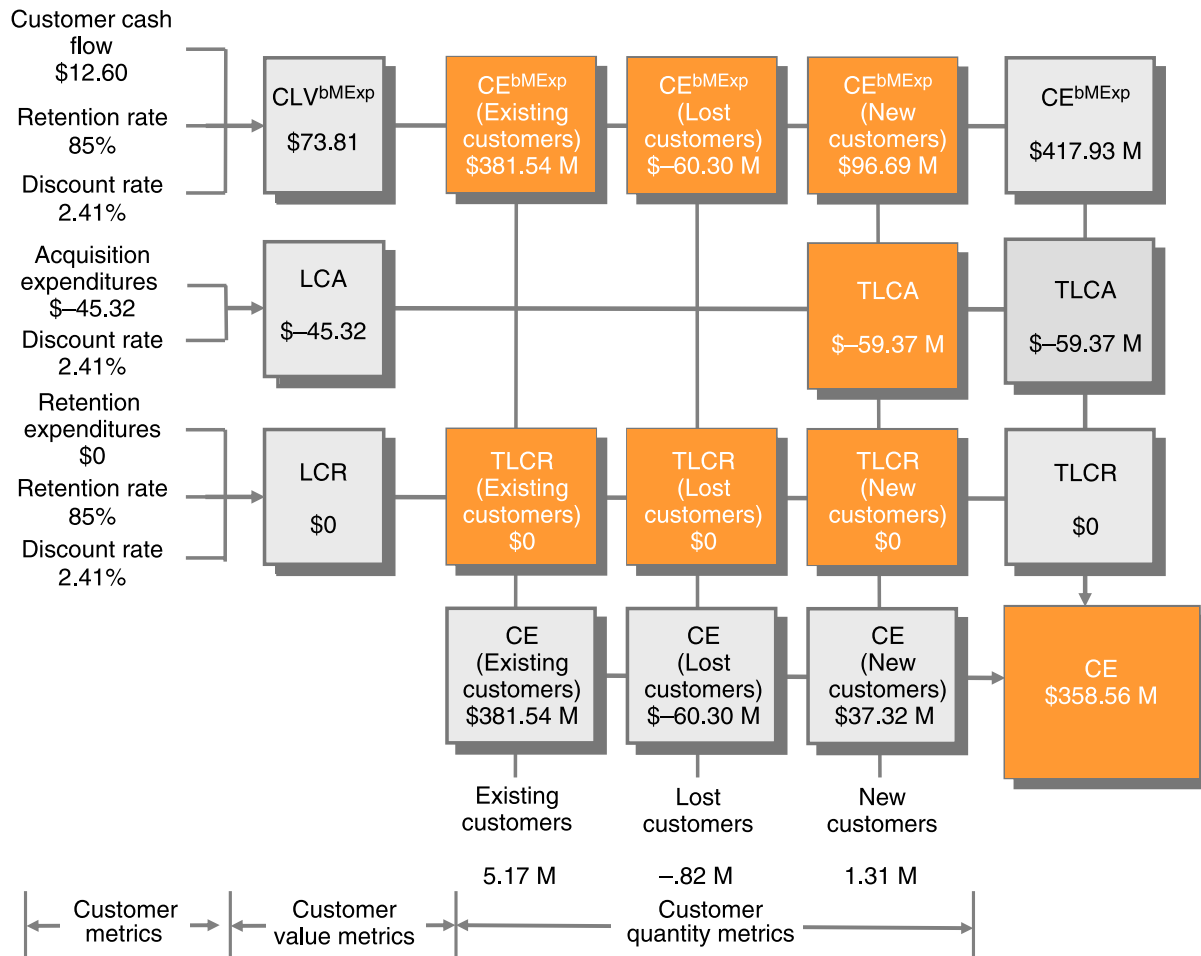

Notes: CE = customer equity, CLV<sup>bME</sup> = customer lifetime value before marketing expenditures, LCA = lifetime acquisition expenditures, LCR = lifetime retention expenditures, TLCA = total lifetime acquisition expenditures, and TLCR = total lifetime retention expenditures.

In Figure 5, we illustrate the development of customer equity over time. Except for Q3 2005, customer equity always increases over time. Because it monitors customer equity over time, the “Customer Equity Statement” provides investors with information about the value of the customer base, as well as an illustrative overview of customer metrics, the value of the customer base, and its components. However, it does not indicate the sources of change in customer equity over time, which would enhance any analysis by giving investors insights into how much and, as a result, of which metric the value of the customer base has changed. More detailed statements about the firm’s customer management activities appear in the “Customer Equity Flow Statement.”

**Netflix's “Customer Equity Flow Statement”**

Following from Figure 4, we develop Figure 6 to depict Netflix’s total change in customer equity, its components, and its customer metrics in Q2–Q3 2006. Customer equity changed by \$48.10 million, which reflects a change in customer equity before marketing expenditures of \$60.44 mil-

**FIGURE 5**  
**Customer Equity Over Time**

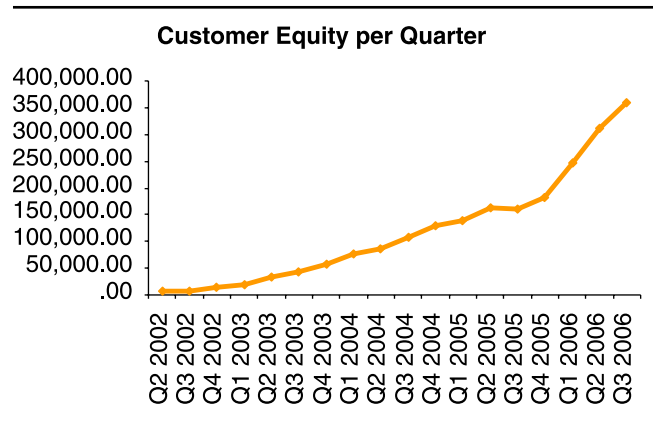

lion and a change in total lifetime acquisition expenditures of -\$12.34 million (i.e., total lifetime acquisition expenditures increased). The change in customer equity before marketing expenditures comprises three components: change in

**FIGURE 6**  
**Netflix's Customer Flow Equity Statement (Q2–Q3 2006): Components View**

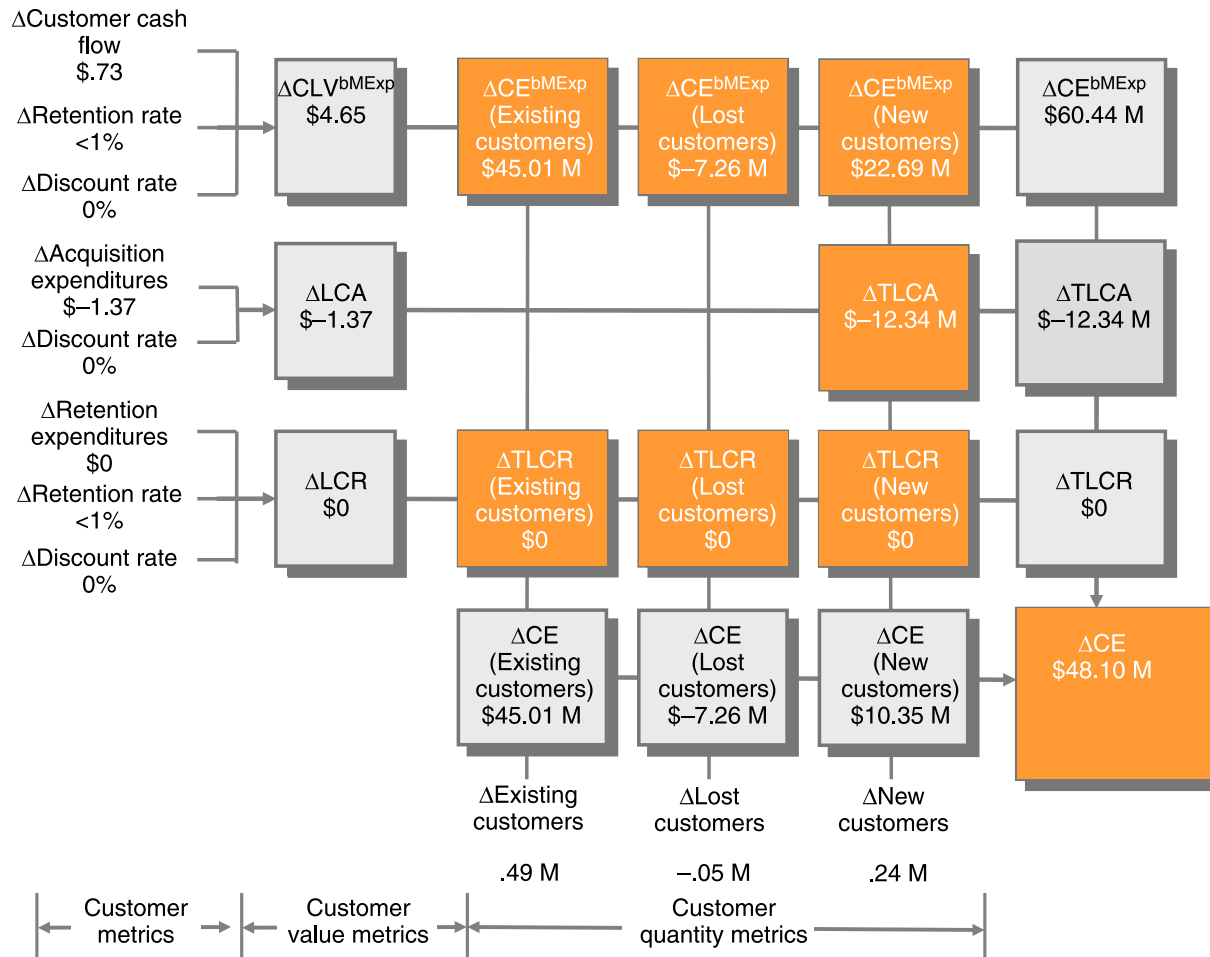

Notes:  $\Delta$ CE = customer equity,  $\Delta$ CLV<sup>bMExp</sup> = customer lifetime value before marketing expenditures,  $\Delta$ LCA = lifetime acquisition expenditures,  $\Delta$ LCR = lifetime retention expenditures,  $\Delta$ TLCA = total lifetime acquisition expenditures, and  $\Delta$ TLCR = total lifetime retention expenditures.

customer equity before marketing expenditures of existing customers (\$45.01 million), lost customers (-\$7.26 million), and new customers (\$22.69 million).

Furthermore, Figure 6 indicates the changes in customer metrics, customer value metrics, and customer quantity metrics and thus summarizes what has happened during the period and the forward-looking effects of those changes (i.e., changes in customer equity). For example, investors might note that Netflix increased its existing customers (.49 million), lost more customers than in Q2 2006 (-.05 million), and gained more customers than it did in Q2 2006 (.24 million) and therefore increased the value of the whole customer base, primarily because its average customer cash flow (\$.73) increased during that period.

In addition to decomposing changes in customer equity for several components, investors might want to know which metrics caused those changes, as we provide in Table 4, which includes the total effect (total change), value effects (changes due to changes in customer value metrics), quantity effects (changes due to the number of existing, lost, and new customers), and interaction effects (changes

due to simultaneous changes in customer value and quantity metrics).

According to Table 4, the major sources of Netflix's increased customer equity in Q2–Q3 2006 (\$48.10 million) are positive value (\$22.35 million) and quantity (\$23.22 million) effects. Furthermore, the change in customer cash flow increases customer equity by \$21.98 million, supported by the increase in customer lifetime (\$1.84 million) but partly compensated for by higher acquisition expenditures (-\$1.47 million). In addition to this decomposition, management can explain why those changes occurred and what it plans to do in the future.

According to Netflix's financial statements, monthly revenues per subscriber declined because of the continued popularity of lower-cost subscription plans. However, the cost of subscription revenues (revenue-sharing expenses, amortization of the DVD library, and postage and packaging expenses) and fulfillment (expenses incurred in operating and staffing shipping and customer service centers, including receiving, inspecting, and warehousing the library and credit card fees) declined as a percentage of revenue.

**TABLE 4**  
**Netflix's Customer Flow Equity Statement (Q2–Q3 2006): Effects View**

	Q1–Q2 2006	Q2–Q3 2006	Trend
<b>Total Effect (in Thousands of Dollars)</b>	63,543.91	48,098.98	↘
<i>Value Effects</i>	27,342.54	22,351.47	↘
Customer cash flow	28,515.11	21,977.91	↘
Customer lifetime	6,373.39	1,839.46	↘
Acquisition expenditures	–7,545.96	–1,465.90	↗
<i>Quantity Effects</i>	32,166.34	23,218.85	↘
Lost customers	–47,269.71	–56,503.34	↘
New customers	79,436.05	79,722.18	↗
<i>Interaction Effects</i>	4,035.03	2,528.67	↘
Lost customers	–5,664.43	–3,782.62	↗
Customer cash flow	–4,494.67	–3,473.78	↗
Customer lifetime	–1,169.75	–308.84	↗
New customers	8,949.88	6,179.70	↘
Customer cash flow	6,270.28	5,569.95	↘
Customer lifetime	2,679.60	609.75	↘
Lifetime			
Customer cash flow	1,753.39	234.67	↘
Other	–1,003.80	–103.08	↗

Netflix explains this decline with the lowered cost per paid shipment, which includes a drop in the percentage of DVDs mailed to subscribers subject to revenue-sharing agreements. The firm also notes the decline in overall usage (i.e., fewer monthly movie rentals per average subscriber) and increased operational efficiencies. These changes increase our calculated customer cash flow. Finally, the minor increase in retention rate appears to stem from the firm's price parity with Blockbuster, as well as service improvements (e.g., more titles, better recommendations).

Furthermore, the quantity effects in Q2–Q3 2006 are positive (\$23.22 million), indicating that Netflix grows its customer base. The positive interaction effects (\$2.53 million) also suggest that the cash flow and retention rate increases prompt positive customer cash flow and lifetime effects for existing and new customers but results in a negative effect for lost customers.

To enhance understandability, Table 4 also includes trends compared with the previous quarter. Thus, investors might observe changes in the customer equity trends over time. For example, a comparison of Q2–Q3 2006 with Q1–Q2 2006 (see Table 4) shows that Netflix's customer equity growth slows down. Although there are positive trends in acquisition expenditures and new customers, the trends of customer cash flows, customer lifetime, and lost customers are deteriorating. These trends allow investors to evaluate the firm's ability to solve previous periods' problems or its potential to outperform its previous growth in customer equity.

## Discussion and Conclusion

We emphasize that the reporting of forward-looking customer metrics addresses the demand for additional information that facilitates investors' decisions. Therefore, we propose a means to report customer equity that matches financial reporting criteria and enables investors, creditors, and other consumers of financial reports to understand the

firm's capability to generate shareholder value. In this sense, our research contributes to recent discussions about financial reporting and enables investors to monitor a firm's performance with respect to its primary assets. Moreover, it contributes to the discussion about marketing accountability and might support marketing's reentry into the boardroom because it aligns customer management with corporate goals and the investor's perspective.

For the specific purpose of reporting, we focus on the value of the current customer base and its changes over time. Customer-based firm valuation would be a natural extension, and the value of future customers must then be taken into account. A rather limited number of studies exist in this area. Kim, Mahajan, and Srivastava (1995) estimate the value per pop (i.e., the number of people living in a service area) using subscriber data in the cell phone industry. They find that their model is able to capture and predict this value well. Gupta, Lehmann, and Stuart (2004) use publicly available customer data from five firms to estimate customer equity. They find that their estimates of customer equity are reasonably close to the market value for three of the five firms (exceptions were Amazon.com and eBay). Libai, Muller, and Peres (2007) replicate their model using a Bass diffusion model with customer defection. Their results confirm Gupta, Lehmann, and Stuart's (2004) findings. Rust, Lemon, and Zeithaml (2004) use a survey of 100 airline customers to estimate CLV for American Airlines. Using this estimate and the total number of airline passengers, they estimate the overall customer value of American Airlines in 1999 as \$7.3 billion. Because this estimate does not include international traffic and other nonflight sources of revenue, it is reasonably close to the \$9.7 billion market value of American Airlines at that time. We believe that if more firms follow the example of companies such as Netflix and disclose better information about their customer base, models for calculating and decomposing the value of the customer base (i.e., customer equity) and customer-based firm valuation will gain more importance in practice.

The proposed technique for customer equity reporting permits a wide range of models for calculating CLV and customer equity. We introduce a parsimonious model that reflects our data availability for calculating and decomposing customer equity in application to data from Netflix. The provided calculations and decomposition of customer equity reveal a clear understanding of the health of Netflix's customer base to investors, especially because they also analyze the influence of changes in customer metrics on the value of the customer base. As such, our model is both diagnostic and forward looking.

Our research also contains limitations, which suggest opportunities for additional study. Although we develop our reporting technique for a broad range of firms, we study only a single firm in depth. Further research might analyze the value of the customer base of additional firms and industries to examine whether industry-specific patterns of changes emerge in terms of customer metrics. Such an analysis could also provide a benchmark for developments across not only time but also industries. In addition, our specific calculation of CLV entails just one possible method that requires only a limited amount of information, whereas the general framework also permits several other specifications. We explain why violations of the assumptions we need to make should lead only to minor bias in the results, but additional research could analyze our arguments in greater depth. Further research might use our ideas when other types of data are available. For example, although individual customer information is sensitive and firms might be reluctant to disclose them in financial reports, aggregated segment-level statistics (e.g., high, middle, and low CLVs or the variance of average CLVs and other customer metrics across segments) may lead to additional insights for investors. Thus, instead of using only customer averages—across all the firm's customers—when reporting CLV, acquisition or retention expenditures, and customer equity, firms might also report the variance of these averages (even on a segment level) to account for heterogeneity across customers. Moreover, because of the limited amount of data, our approach does not include competitive effects. Using a Markov switching-matrix approach to model CLV would enable us to design a model that contains both customer acquisition and retention in the context of brand switching (e.g., Rust, Lemon, and Zeithaml 2004). Further research might incorporate this, if the necessary data are available.

An extended approach could also incorporate varying future acquisition or retention expenditures as well as discount and retention rates because they might change (e.g., Gupta and Lehmann 2005). Likewise, our specification could be extended to capture additional aspects that could be incorporated as additional customer metrics, such as cross- and up-selling projections. Moreover, further research could examine how our technique should be adjusted for noncontractual relationships because we focus on firms with contractual relationships, which can easily determine the number of existing and lost customers at a particular point in time. Additional research might also examine implementation issues of our approach. For example, it would be worthwhile to know how to stimulate usage

of such reporting techniques for a firm's investor-relations activities, which information they already compute and track over time, and which level of metrics they are willing to disclose. Thus, activity-based costing approaches might avoid possible endogeneity problems related to our way of computing acquisition or retention expenditures.

Future approaches could also incorporate additional customer performance metrics. For example, metrics of customer value creation and marketing efficiency may offer additional information on the firm's customer management activities over time. Examples are metrics that indicate the creation of value through new customer acquisition activities or demonstrate changes in the efficiency of investments in customer acquisition or retention activities over time. Further research might examine whether additional metrics provide better diagnostics of future firm performance than current metrics.

We propose a reporting technique that enables investors to analyze the situation of the firm better and to identify the metrics responsible for changes in customer equity. However, we do not intend to explain why certain metrics have changed; that job is up to management, as are explanations of future plans (IASB 2005). Our reporting technique visualizes the long-term effects of changes for external recipients of financial reports. Internally, firms should employ models that diagnose the reasons for particular changes in customer metrics in much more detail (e.g., Rust, Lemon, and Zeithaml 2004). Further research could explore the advantages of combining our reporting technique with such detailed internal models. A particular challenge might be to determine how these combinations best meet the criteria for financial reporting—namely, future orientation, decomposition, objectivity, comparability, simplicity, and cost effectiveness.

## Summary

Recent discussions in accounting have demanded the need for additional information that facilitates investors' decision making and meets the objectives of financial reporting. Forward-looking customer metrics are necessary and useful as a managerial tool and thus should also be reported in financial statements to enable investors to understand clearly the firm's capability to generate shareholder value. An external reporting technique that addresses the consequences of a firm's customer management activities completes the concept of value-based customer management because it aligns customer management with corporate goals and the investor's perspective. We develop a reporting technique that provides a starting point for considering the value of the customer base in a firm's financial report, especially in the "MD&A" or "Management Commentary" sections. We emphasize that this reporting technique provides a supplement and complement to current information in financial statements, as demanded by the SEC and IASB. Because marketing literature includes in-depth discussions of the concepts of customer and brand equity, marketing academics should take a leading role in transferring that knowledge to other areas, such as accounting or finance.

## REFERENCES

- Ambler, Tim (2000), *Marketing and the Bottom Line*. London: Financial Times/Prentice Hall.
- Amir, Eli and Baruch Lev (1996), "Value-Relevance of Non-financial Information: The Wireless Communication Industry," *Journal of Accounting and Economics*, 22 (1-3), 3-30.
- Berger, Paul D. and Nada L. Nasr (1998), "Customer Lifetime Value: Marketing Models and Applications," *Journal of Interactive Marketing*, 12 (1), 18-30.
- Blattberg, Robert C. and John Deighton (1996), "Managing Marketing by the Customer Equity Test," *Harvard Business Review*, 74 (July-August), 136-44.
- Deloitte (2006), *Global Capital Markets and the Global Economy: A Vision from the CEOs of the International Audit Networks*. London: Deloitte.
- Fader, Peter S. and Bruce G.S. Hardie (2006), "Customer-Base Valuation in a Contractual Setting: The Perils of Ignoring Heterogeneity," working paper, London Business School.
- FASB (1978), *Statement of Financial Accounting Concepts No. 1: Objectives of Financial Reporting by Business Enterprises*. Stamford, CT: FASB.
- (1980), *Statement of Financial Accounting Concepts No. 2: Qualitative Characteristics and Accounting Information*. Stamford, CT: FASB.
- (2000), *Statement of Financial Accounting Concepts No. 7: Using Cash Flow Information and Present Value in Accounting Measurements*. Stamford, CT: FASB.
- Fischer, Marc (2007), "Valuing Brand Assets: A Cost-Effective and Easy-to-Implement Measurement Approach," Marketing Science Institute Working Paper No. 07-107.
- Fornell, Claes, Sunil Mithas, Forrest V. Morgeson, and M.S. Krishnan (2006), "Customer Satisfaction and Stock Prices: High Returns, Low Risk," *Journal of Marketing*, 70 (January), 3-14.
- Gupta, Sunil and Donald R. Lehmann (2003), "Customers as Assets," *Journal of Interactive Marketing*, 17 (1), 9-24.
- and ——— (2005), *Managing Customers as Assets*. Upper Saddle River, NJ: The Wharton School Publishing.
- , ———, and Jennifer A. Stuart (2004), "Valuing Customers," *Journal of Marketing Research*, 41 (February), 7-18.
- IASB (2004), *Framework for the Preparation and Presentation of Financial Statements*. London: IASB.
- (2005), "Management Commentary." London: IASB.
- Ittner, Christopher D. and David F. Larcker (1998), "Are Non-financial Measures Leading Indicators of Financial Performance? An Analysis of Customer Satisfaction," *Journal of Accounting Research*, 36 (3, Supplement), 1-35.
- , ———, and Taylor Randall (2003), "Performance Implications of Strategic Performance Measurement in Financial Service Firms," *Accounting, Organizations and Society*, 28 (7-8), 715-41.
- Kim, Namwoon, Vijay Mahajan, and Rajendra K. Srivastava (1995), "Determining the Going Market Value of a Business in an Emerging Information Technology Industry: The Case of the Cellular Communications Industry," *Technological Forecasting and Social Change*, 49 (3), 257-79.
- Kumar, V. and Morris George (2007), "Measuring and Maximizing Customer Equity: A Critical Analysis," *Journal of the Academy of Marketing Science*, 35 (2), 157-71.
- , Girish Ramani, and Timothy Bohling (2004), "Customer Lifetime Value Approaches and Best Practice Applications," *Journal of Interactive Marketing*, 18 (3), 60-72.
- and Werner Reinartz (2005), *Customer Relationship Management: A Databased Approach*. New York: John Wiley & Sons.
- Libai, Barak, Eitan Muller, and Renana Peres (2007), "The Influence of Attrition on the Growth and Equity of Competitive Services," Marketing Science Institute Working Paper No. 07-109.
- Marketing Science Institute (1999), "Value of the Brand," workshop at Marketing Science Institute Conference on Marketing Metrics, Washington, DC (October 6-8).
- McGovern, Gail J., David Court, John A. Quelch, and Blair Crawford (2004), "Bringing Customers into the Boardroom," *Harvard Business Review*, 82 (11), 1-10.
- Nagar, Venky and Madhav V. Rajan (2005), "Measuring Customer Relationships: The Case of the Retail Banking Industry," *Management Science*, 51 (6), 904-919.
- Netflix (2006), *SEC Filing 10-Q-Form*. Los Gatos, CA: Netflix.
- Payne, Adrian and Pennie Frow (2005), "A Strategic Framework for Customer Relationship Management," *Journal of Marketing*, 69 (October), 167-76.
- PricewaterhouseCoopers (2005), *Trends 2005: Good Practices in Corporate Reporting*. London: PricewaterhouseCoopers.
- Reinartz, Werner J. and V. Kumar (2000), "On the Profitability of Long Lifetime Customers: An Empirical Investigation and Implications for Marketing," *Journal of Marketing*, 64 (October), 17-35.
- and ——— (2003), "The Impact of Customer Relationship Characteristics on Profitable Lifetime Duration," *Journal of Marketing*, 67 (January), 77-99.
- , Jacquelyn S. Thomas, and V. Kumar (2005), "Balancing Acquisition and Retention Resources to Maximize Customer Profitability," *Journal of Marketing*, 69 (January), 63-79.
- Rust, Roland T., Katherine N. Lemon, and Valarie A. Zeithaml (2004), "Return on Marketing: Using Customer Equity to Focus Marketing Strategy," *Journal of Marketing*, 68 (January), 109-127.
- Ryals, Lynette J. (2005), "Making Customer Relationship Management Work: The Measurement and Profitable Management of Customer Relationships," *Journal of Marketing*, 69 (October), 252-61.
- Said, Amal A., Hassan R. HassabElnaby, and Benson Wier (2003), "An Empirical Investigation of the Performance Consequences of Nonfinancial Measures," *Journal of Management Accounting Research*, 15 (1), 193-223.
- SEC (2003), "Commission Guidance Regarding Management's Discussion and Analysis of Financial Condition and Results of Operations," Release Nos. 33-8350; 33-48960, FR-72. New York: SEC.
- Smith, Rodney E. and William F. Wright (2004), "Determinants of Customer Loyalty and Financial Performance," *Journal of Management Accounting Research*, 16 (1), 183-205.
- Srinivasan, Shuba and Dominique M. Hanssens (2007), "Marketing and Firm Value: Metrics, Methods, Findings and Future Directions," working paper, Gary Anderson School of Management, University of California, Riverside.
- Venkatesan, Rajkumar and V. Kumar (2004), "A Customer Lifetime Value Framework for Customer Selection and Resource Allocation Strategy," *Journal of Marketing*, 68 (October), 106-125.